

Solid State Relays - PCB Mount: LS

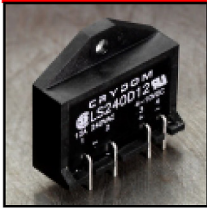

Features

SCR output • 8-12Amp • 24-280 Vrms • AC Switching • SIP mount
• Metal baseplate • 5 and 24 VDC control • High current surge ratings.

Product	INPUT SPECIFICATIONS		OUTPUT SPECIFICATIONS		
	Control Voltage Range	Load Current	Switching Voltage Type	Turn On	Load Voltage Range
LS240D12	4-10 Volts DC	0.15-12 Amps RMS	AC	Zero cross	24-280 Volts RMS
LS240D12R	4-10 Volts DC	0.15-12 Amps RMS	AC	Random	24-280 Volts RMS
LS240D8	4-10 Volts DC	0.15-8 Amps RMS	AC	Zero cross	24-280 Volts RMS
LS240D8R	4-10 Volts DC	0.15-8 Amps RMS	AC	Random	24-280 Volts RMS
LSE240D12	20-28 Volts DC	0.15-12 Amps RMS	AC	Zero cross	24-280 Volts RMS
LSE240D12R	20-28 Volts DC	0.15-12 Amps RMS	AC	Random	24-280 Vots RMS
LSE240D8	20-28 Volts DC	0.15-8 Amps RMS	AC	Zero cross	24-280 Volts RMS

LSE240D8R

20-28 Volts DC

0.15-8
Amps RMS

AC

Random

24-280
Volts RMS

- PCB Mount
- High Surge Rated SCR Output
- Metal Baseplate
- Application include Motor, Heater, Lamp and Solenoid Switching
- No Moving Parts
- Zero Volt or Instant Switch On
- 24Vdc Control Available (Suffix E)

Crydom's LS family of SPST-NO relays achieves the highest power switching capability in a PC-mounted air-cooled package. Output consists of an SCR AC switch and is available in zero-cross and random turn-on (Suffix R).

Advanced features include exceptional steady state current, plus high surge ratings. Metal baseplate design for direct attachment of external heatsink to achieve higher current rating.

Manufactured in Crydom's ISO 9001 Certified facility for optimum product performance and reliability.

OUTPUT SPECIFICATIONS ①	Model	LS240D8	LS240D8R	LS240D12	LS240D12R
Operating Voltage (47-63 Hz) [Vrms]		24-280	24-280	24-280	24-280
Load Current Range [Arms] ③		0.15-8	0.15-8	0.15-12	0.15-12
Transient Overvoltage [Vpk]		600	600	600	600
Max. Surge Current, (16.6ms) [Apk]		80	80	120	120
Max. On-State Voltage Drop @ Rated Current [Vpk]		1.6	1.6	1.6	1.6
Maximum I ² t for Fusing, (8.3 msec.) [A ² sec]		26	26	60	60
Max. Off-State Leakage Current @ Rated Voltage [mArms]		0.1	0.1	0.1	0.1
Min. Off-State dv/dt @ Max. Rated Voltage [V/μsec] ②		500	500	500	500
Max. Turn-On Time [ms]		1/2 Cycle	0.1	1/2 Cycle	0.1
Max. Turn-Off Time		1/2 Cycle	1/2 Cycle	1/2 Cycle	1/2 Cycle
Power Factor (Min.) with Max. Load		0.5	0.5	0.5	0.5

INPUT SPECIFICATIONS ①

Nominal Control Voltage	5 Vdc	24 Vdc
Control Voltage Range	4-10 Vdc	20-28 Vdc
Max. Turn-On Voltage	4.0 Vdc	20 Vdc
Min. Turn-Off Voltage	1.0 Vdc	1.0 Vdc
Nominal Input Impedance	270 Ohm	1500 Ohm
Typical Input Current @ Nominal Voltage	15 mAdc	15 mAdc

GENERAL NOTES

- ① All parameters at 25° C unless otherwise specified.
 ② Off-State dv/dt test method per EIA/NARM standard RS-443, paragraph 13.11.1
 ③ See current derating curve on page 2

© 2007 CRYDOM Inc., Specifications subject to change without notice.

APPROVALS

UL E116950
 CSA LR 816889
 TUV E2072777



GENERAL SPECIFICATIONS

Dielectric Strength 50/60Hz Input/Output/Base	2500 Vrms
Insulation Resistance (Min.) @ 500 Vdc	10 ⁹ Ohm
Max. Capacitance Input/Output	10 pF
Ambient Operating Temperature Range	-30 to 80°C
Ambient Storage Temperature Range	-30 to 125°C

MECHANICAL SPECIFICATIONS

Weight: (typical)	0.6 oz. (17g)
Encapsulation:	Thermally Conductive Epoxy

AVAILABLE OPTIONS

E 24Vdc Input
Example: LSE240D12R

MECHANICAL DIMENSIONS

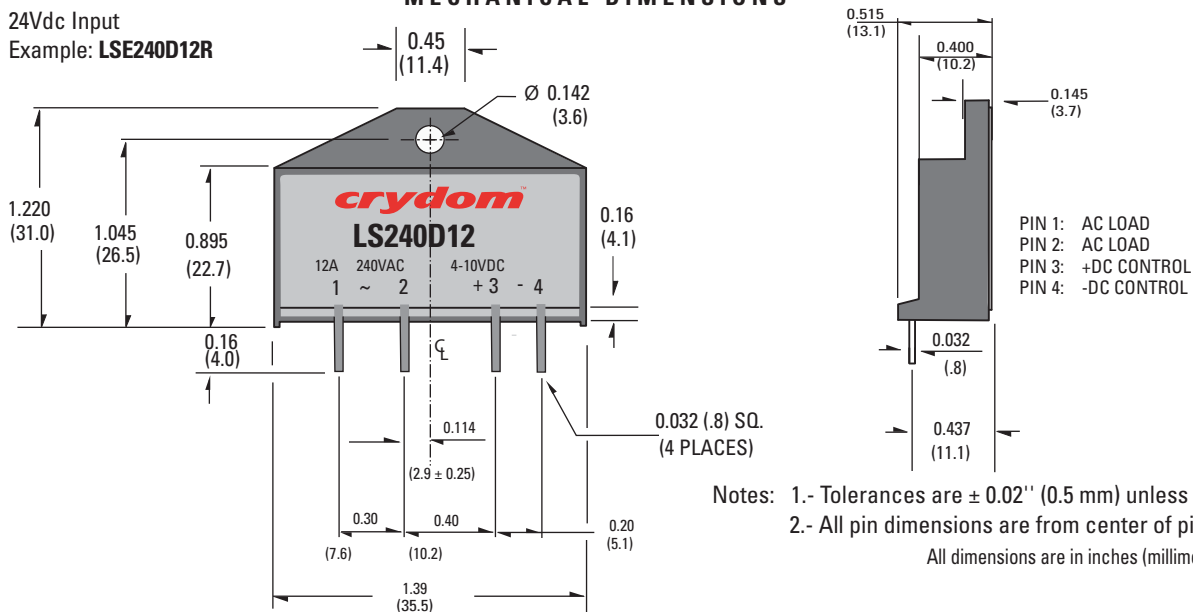

CURRENT DERATING CURVES

